

Mentors of Pre-service Teachers: Relationships between Mentoring Approach, Self-efficacy and Effort

Abstract

Purpose: This article discusses how different styles of mentoring in teacher education relate to mentor characteristics. Pre-service teachers often want practical advice. However, in Norway, school mentors have traditionally been encouraged to promote reflection rather than offering advice. This article seeks to explore the relationship between mentors' support for reflection-based and clear mentoring (a relatively direct approach to mentoring) and mentors' self-efficacy and effort.

Design/methodology/approach: Using structural equation modelling of cross-sectional survey data (from 272 school mentors), the researchers in this study tested empirical interrelations between reflection-based mentoring, clear mentoring, mentor efficacy and effort. Clear mentoring was a reasonably consistent construct, while reflection-based mentoring was a more elusive concept.

Findings: Effort was associated with support for reflection, while self-efficacy was moderately related to clear mentoring and reflection-based mentoring. The results illustrate that reflection-based methods are demanding for mentors. If direct approaches are more effective, additional evidence would be required to support mentor training that heavily emphasises reflection.

Research limitations/implications: Longitudinal and quasi-experimental studies are needed to support inferences about causality. Variable omission may have influenced the models. More research is needed to better understand the concept of reflection-based mentoring.

Originality/value: This article contributes to the mentoring field by examining mentors' preference for reflection-based and clear mentoring and how such preferences are related to self-efficacy and effort. It also contributes to general and theoretical discussions about the relationships between beliefs about mentoring and mentor characteristics.

Keywords: clear mentoring, reflection-based mentoring, mentor self-efficacy, mentor effort, practicum

Research paper

Introduction

In teacher education, placing pre-service teachers in schools is a key element in preparing them to become teachers. In their school practice (practicum), pre-service teachers combine elements of on-campus instruction in pedagogy and subject matter didactics. School-based mentors play an important role in contributing to pre-service teachers' development. However, there are conflicting opinions on how mentors can best contribute to mentees' professional development (Harrison *et al.*, 2006; Hobson and Malderez, 2013). Since the influence mentoring has on mentees is complex and can result in contrasting outcomes, knowing various mentoring approaches is paramount (Augustiniene and Ciuciulkiene, 2013; Brondyk and Searby, 2013; Payne and Huffman, 2005). Mentoring has the potential to affect mentees both positively (Dahl, 2006; Helms-Lorenz *et al.*, 2013; Smith and Ingersoll, 2004) and negatively (Harrison *et al.*, 2006; Hobson *et al.*, 2009; Hobson and Malderez, 2013; Hobson and McIntyre, 2013).

The purpose of this article is to answer our research question: How is mentors' support for different forms of mentoring associated with mentors' self-efficacy and effort in their role? In earlier work, we explored mentors' support for different forms of mentoring (Lejonberg, 2016; Lejonberg *et al.*, 2015) and how such styles can affect mentees (Lejonberg and Tiplic, 2016). The work presented in this article contributes to the field of mentoring by investigating mentors' preference for reflection-based mentoring and clear mentoring, by illuminating relationships between such variables and mentor self-efficacy and effort. In this study, we use clear mentoring as mentoring characterised by "clear communication of feedback and advice", an approach where mentors share their opinions and experiences, give instructions and express their judgements on mentees' practice (Lejonberg and Tiplic, 2016, p. 290). Reflection-based mentoring is characterised by mentors who communicate that there are many possible ways to be a good teacher and give mentees extensive opportunities to reflect upon their own practice and beliefs about learning and teaching. Quantitative research has seldom focused on the content and quality of pre-service teacher-mentoring.

This article also represents a methodological and theoretical contribution to the field. The analysis was carried out using structural equation modelling, an approach that allows estimation of relationships between variables. With this methodological approach, there is often uncertainty related to possible causality. Usually, the causal arrows are assigned by the researchers on theoretical grounds. In this case, however, the researchers present and discuss all included latent variables as both dependent and independent. In this way, the researchers also aim to contribute to general and theoretical discussions about relationships between beliefs about mentoring and mentor characteristics.

Context

In Norway, teacher education programmes vary in structure. However, all pre-service teachers in teacher education for lower secondary (students aged 13 to 15) and upper secondary schools (16 to 18) attend 60 to 100 days of field placement. In some programmes, practicum consists of two relatively

long periods carried out in one year. In other programmes, the days are divided among several periods during a five-year master study. Student assessments are a shared responsibility between school-based mentors and the teacher education institution. The students are usually mentored by several mentors during their practicum. Mentoring is often carried out by teachers in practice schools with expertise in the pre-service teacher's academic field. Mentors are expected to have research and development qualifications as well as training in mentor education (The Norwegian Government, 2010; The Department of Education and Research, 2017). If they have not completed mentor education before assuming this role, it is expected that mentors will enrol in such a programme (The Department of Education and Research, 2017).

Researchers have found that mentoring practices differ greatly between countries, and these differences are reflected in mentors' beliefs about mentoring (Fenwick, 2013; Kullman, 1998; Orland-Barak, 2014). Many have argued that mentees should be supported through mentors facilitating mentees' reflection (Clutterbuck, 2004; Feiman-Nemser, 2001; Hobson *et al.*, 2009; Irby, 2014; Kram, 1988). Reflection-based approaches have a stronghold in Norway (Lejonberg, 2016). The theoretical foundation for Norwegian mentoring traditions are described as hegemonic and static, leaving little room for alternative approaches to mentoring (Skagen, 2016).

The Norwegian government's attempts to enhance the quality of mentoring through formal mentor education are "unique in the European and international context" (Smith and Ulvik, 2014, p. 265). Teachers who undertake mentor education to professionalise their mentoring practices are described as having a "profession within the profession" (Ulvik and Smith, 2011, p. 82). In Scandinavian mentor education, reflection-based approaches have traditionally had a privileged position (Bjerkholt, 2013; Lindgren, 2007; Skagen, 2013, 2016) and are strongly endorsed in the study literature of mentor training programmes (Rambøll, 2016). The heavy dependence on mentees' reflection in conversations has been a predominant paradigm since the 1980s (Mathisen and Bjørndal, 2007). Mentors become familiar with ideas consistent with reflection-based mentoring through mentor education (Lejonberg *et al.*, 2015). Such preferences have also been endorsed by researchers, arguing that such approaches may encourage mentors to develop their own mentoring practices and ground their practices in theory and scientific methods (Bruner, 1996; Fang, 1996; Furlong, 1995; Hyland, 1992; Ulvik and Sunde, 2013).

Contrasting different approaches to mentoring

Formal arrangements structuring the role of mentors are likely to affect mentors' work practices. Hobson and Malderez (2013) suggested that a form of mentoring where mentors judge mentees based on mentors' opinions may be less likely to occur in Scandinavia, since mentors are supposed to support and develop rather than judge mentee performance based on given standards. Many Norwegian mentors who meet the pre-service teachers in the practical phase of their training also work with newly qualified teachers where they do not assess their mentees. Mentor education is usually one

integrated program, regardless of whether mentors work with pre-service teachers or newly qualified teachers. Lejonberg *et al.* (2015) presented evidence that such mentor education contributes to mentors' beliefs about mentoring. More specifically, their results indicated that mentors who have conducted mentor education are less likely to support a form of mentoring characterised by clear advice and evaluations of mentees' classroom practises. However, Norwegian mentees actively seek their mentors' opinions and ask for concrete advice from their mentors (Joram, 2007; Sundli, 2002). Such findings indicate that there is an incongruence between what mentees seek in mentoring and approaches to mentoring emphasised in mentor education. The stronghold of reflection-based mentoring makes Norway an interesting context in which to investigate mentors' perceptions of mentoring and mentors' self-efficacy and effort.

Assessing someone else based on one's own practical experience is described as a less complex approach than using the competencies and preferences of the mentee, encouraging his or her professional development (Lejonberg *et al.*, 2015; Loughran and Russell, 1997). In literature about mentoring beginning teachers, mentors are often encouraged to be "non-directive", "developmental" and "collaborative" rather than "directive", "judgmental" and "prescriptive" (Kullman, 1998, p. 474). Hobson and Malderez (2013) claimed that in contrast to developmental mentoring, mentoring through too much evaluation, advice, feedback and criticism may become an obstacle to mentees' wellbeing and professional development. Other studies have suggested that different forms of mentoring lead to diverse outcomes. For example, several contributions have claimed that mentoring that follows a constructivist style is more developmental (Furlong, 1995; Richter *et al.*, 2013; Wildman *et al.*, 1992). Richter *et al.* (2013) found that "mentoring that follows constructivist rather than transmissive principles" (p. 166) encourages mentees' self-efficacy. Such findings can be interpreted as arguments for reflection as a key element of mentoring. In contrast to the findings reported by Richter *et al.* (2013), however, Lejonberg and Tiplic (2016) presented results indicating that reflection-based mentoring is negatively related to mentees' self-efficacy. In their work, transmissive-inspired approaches are related to higher reported levels of self-efficacy. Such mixed evidence related to which approaches to mentoring are better for mentees call for further investigations of mentors' preferences and practices.

Furthermore, others have found that teachers' educational beliefs affect their practices (Berger *et al.*, 2018; Fang, 1996; Reeve, 2009). Considering such findings, insights concerning mentors' preferred approaches to mentoring and characteristics related to mentors and their work are of great potential relevance. Given that the mentoring tradition in Scandinavia underlines reflection-based mentoring as the foundation of mentees' professional development, we may imagine that mentors who feel confident in their ability to function as mentors will share values consistent with those of reflection-based mentoring. However, despite the focus on the importance of reflection-based mentoring in theoretical contributions and mentor education, researchers in Norway have presented findings indicating that mentors use clear mentoring techniques more often than we may think (Sundli

2001, 2002). Sundli (2002) found that although mentors reported that they perceive reflection-based mentoring as the most potent source of mentees' professional development, their actual mentoring practice contradicts such ideals. Such findings indicate that mentors employ a more nuanced approach to mentoring.

Several studies have shown that mentees seek concrete feedback and advice on how to perform in their daily work, and that mentoring beginning teachers is often focused on technical perspectives and effective methods in teaching (Joram, 2007; Kullman, 1998; Ottesen, 2006; Penny *et al.*, 1996). Therefore, mentors may be prompted to express their personal opinions to accommodate mentees' needs. To facilitate reflection-based mentoring in a way that promotes mentees' professional growth is very demanding (Bjerkholt *et al.*, 2014; Handal, 2007). Although some scholars have argued that mentors should draw on several approaches in their work (Clutterbuck, 2004; Lejonberg, 2016; Mathisen, 2015; Skagen, 2016; Smith, 2016), more knowledge about mentors' beliefs about different styles of mentoring and their characteristics are needed to understand the methods for developing beginning teachers.

Reflection-based mentoring and clear mentoring: examples of different styles of mentoring

Broadly, mentoring is a reciprocal exchange relationship between the mentor and mentee that contributes to the mentee's construction of knowledge with an emphasis on empowering and enabling mentees to perform tasks independently (Blau, 1964; Clutterbuck, 2004; Clutterbuck and Abbott, 2005; Hobson *et al.*, 2009; Lejonberg and Christophersen, 2015; Richard *et al.*, 2009). The researchers in this present study aimed to explore two different approaches to mentoring by investigating mentors' support for reflection-based mentoring and clear mentoring and examining how these are related to self-efficacy in the mentor role and willingness to prioritise their mentorship (effort). To accomplish this, the study operationalised two different forms of mentoring—clear mentoring and reflection-based mentoring.

Clear mentoring is a relationship between an inexperienced pre-service teacher (the mentee) and a relatively experienced one (the mentor) in which the latter aims to contribute to the mentee's professional development by revealing judgements on or evaluations of the mentee's planning and teaching by providing, for example, comments, feedback, advice, praise or criticism (based on the concept of "judgementoring"; Hobson and Malderez, 2013, p. 89). Reflection-based mentoring denotes a relationship between the mentee and the mentor in which the latter aims to contribute to the mentee's professional development by opening room for reflection in conversations with the mentee and encouraging openness to different approaches to teaching (Clutterbuck, 2004; Feiman-Nemser, 2001; Handal and Lauvås, 1983, 1987; Harrison *et al.*, 2006; Hudson, 2005; Kram, 1988).

Researchers have highlighted the development of beginning teachers' ability to work as teachers as a desirable outcome of reflection-based mentoring (Aspfors and Fransson, 2015; Handal and

Lauvås, 1987; Kullman, 1998; Lindgren, 2005). However, others have argued that clear guidance is necessary when entering a profession as complex as teaching (Kirschner *et al.*, 2006; Lejonberg and Tiplic, 2016; Tickle, 1993). Today, arguments about how mentees can benefit from getting clear feedback on their work from mentors is an extension of the growing awareness about how teacher feedback can contribute to learners' development (Grossman *et al.*, 2010; Hartberg *et al.*, 2012; Hattie, 2009; Hattie and Timperley, 2007; Voerman *et al.*, 2015). Lejonberg and Tiplic (2016) investigated how experience with clear mentoring and mentoring characterised by being given many opportunities to reflect and by openness to different approaches to the teacher role are related to mentees' self-efficacy and turnover intentions. The results of that study indicated that mentees who experienced reflection-based mentoring reported lower levels of confidence in their ability as teachers. In contrast, those who were mentored based on clear advice and mentors sharing their own thoughts and perceptions based on practical experience reported higher levels of self-efficacy as teachers and lower levels of intention to quit. Broadly, previous studies have provided conflicting evidence about whether the key elements of reflection-based mentoring promote professional growth among mentees; likewise, conflicting evaluations of the outcomes of mentoring characterised by communication of evaluations, advice and clear feedback have emerged from various analyses.

Mentor self-efficacy and effort

Mentors' self-efficacy: beliefs about own ability to mentor

Bandura (1997) introduced the concept of self-efficacy beliefs, which represent the self-assessment of a person's capability to attain a desired level of performance. Teachers' self-efficacy influences their work in many ways (Canrinus *et al.*, 2012; Skaalvik and Skaalvik, 2007; Tschannen-Moran and Hoy, 2007; Tschannen-Moran *et al.*, 1998). Yost (2006) demonstrated that mentoring in teacher induction could enhance beginning teachers' self-efficacy. Bandura (1997) argued that belief in one's abilities is a powerful driving mechanism of motivating action, levels of commitment and effort invested in a role and perseverance in the face of setbacks. Mentors with low self-efficacy may lack the initiative or motivation needed to improve. Thus, we can infer that promoting mentors' self-efficacy is a useful way to motivate individuals to continue improving in this role. Therefore, the relationship between preferred forms of mentoring and mentors' self-efficacy is worth exploring. Lejonberg *et al.* (2015) found that reported self-efficacy in a mentor was positively associated with stated preferences for judgemental mentoring practices. This aligned with the assumption that mentors' efficacy beliefs in their mentor roles are related to beliefs about mentoring. Therefore, Hypothesis 1 is that mentors' self-efficacy is related to clear mentoring. Furthermore, as discussed in Lejonberg *et al.* (2015), investigating this relationship more closely will determine possible causal relationships between self-efficacy and support for different forms of mentoring. Self-efficacy beliefs can increase if a mentor perceives her or his emphasis on reflection-based mentoring as successful,

which then contributes to the expectations that future performances will likely be proficient. Hypothesis 2 is that mentors' self-efficacy is related to reflection-based mentoring.

Mentor effort: willingness to prioritise mentoring work

The origin of mentors' commitment to teacher education programmes is not directly or explicitly recognised by formal reward systems. Commitment is an attachment to teacher education such that strongly committed mentors identify with and are engaged in the teacher education programme (Lejonberg and Christophersen, 2015; Sandvik *et al.*, forthcoming). LoCasale-Crouch *et al.* (2012) found that mentees who reported feeling more supported in mentoring reported higher levels of reflection after being mentored, suggesting that mentor effort may be related to mentee outcomes. However, outcomes based on mentors' support for different approaches were not illuminated in that study. Furthermore, since school-based mentors' primary job is to teach their students, it is interesting to illuminate their specific obligations concerning the mentor role, as some researchers have done (Bullough, 2005; Lejonberg and Christophersen, 2015).

Others have highlighted how demanding mentors find it to facilitate reflection-based mentoring that promotes mentees' professional growth (Bjerkholt *et al.*, 2014; Handal, 2007). For such reasons, this paper includes mentors' willingness to prioritise their work as mentors in the analysis and hypothesise that mentor effort is related to mentors' support for reflection-based mentoring (Hypothesis 3) and for clear mentoring (Hypothesis 4).

An increase in mentor self-efficacy may also result in greater willingness to prioritise mentoring work, while failures may lower self-efficacy beliefs and result in decreased commitment. We therefore explore the interrelationships between mentors' efforts in the mentoring role and mentor efficacy (Exploratory Assumption 1).

It is a challenge to develop distinct measures of various forms of mentoring. Therefore, we explore how the constructs of reflection-based mentoring and clear mentoring are interrelated (Exploratory Assumption 2).

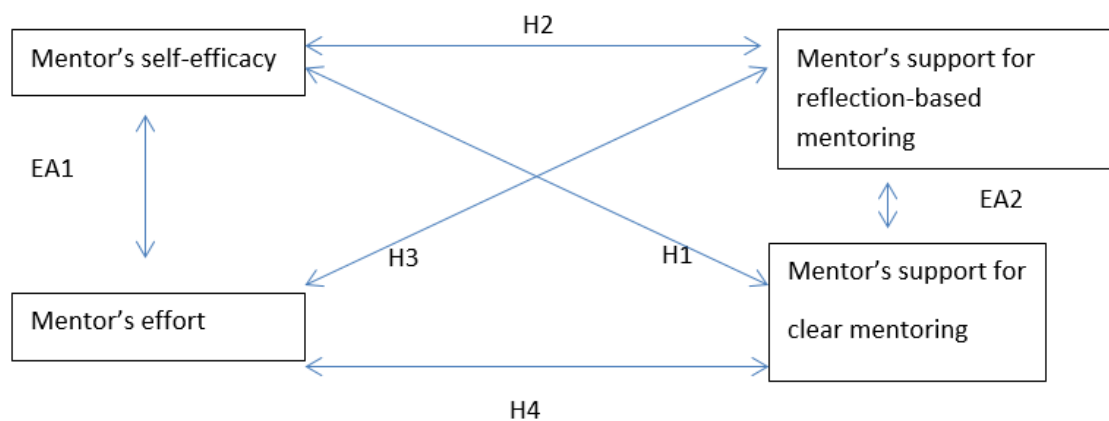

Figure 1. Hypothesised model. H denotes a hypothesis; EA denotes an exploratory assumption.

Methodology

A questionnaire was constructed based on new measurement instruments and instruments previously reported in the literature. The self-efficacy instrument was adapted from previous work (Lejonberg and Christophersen, 2015; Lejonberg *et al.*, 2015). The clear mentoring and reflection-based mentoring instruments were also adapted from previous work (Lejonberg, 2016; Lejonberg and Tiplic, 2016). The effort instrument was developed for the purpose of this study (Haladyna and Rodriguez, 2013). The internal consistency (Cronbach's alpha [CA]) for each of the concepts was satisfactory for three of the four constructs. For the fourth concept, reflection-based mentoring, CA was low. However, the substantial content of the items used in the operationalisation captured different aspects of the broad concept of reflection-based mentoring, and the results are therefore interesting for further instrument development. Reflection-based mentoring appears as an elusive construct in this work (Tschannen-Moran and Hoy, 2001) and was included in the models, represented in two different versions, one with three indicators (see Figures 2 and 3) and one with two (see Figure 4). Data was analysed with structural equation modelling (SEM) in IBM AMOS. Several well-known introductory textbooks and manuals in SEM (Arbuckle and Wothke, 1999; Brown, 2006; Byrne, 2013; Kline, 2005) use examples of indicators that have graded scales with a limited number of values. The indicator scales are used almost without scale levels. Such scales can hardly be perceived as perfect ordinal or interval scales. In this survey, all indicator scales range from 1 to 7. The indicators begin with the words 'To what extent ...' to indicate grading, and only the extremes have labels (totally disagree and totally agree) to indicate scale direction. According to Bentler and Chou (1987), continuous and approximately normally distributed indicators, with at least four ordinal categories, can be analysed as interval scaled variables. This suggests that indicator scales can be perceived as closer to the interval than the ordinal level (Bentler and Chou, 1987; Bishop and Herron, 2015). As little research has developed latent variables relevant to different mentoring approaches, or the relationship between such variables and relevant mentor characteristics, this approach extends knowledge in the field. In this work, we tested the empirical interrelations between reflection-based mentoring and clear mentoring against mentor efficacy and effort in the mentoring role.

Data collection: context and measurements

We tested the hypotheses using data collected from 295 mentors with a self-report survey. Due to some respondents with missing values, 272 mentors were included in the analysis. A questionnaire was developed, printed and distributed. Data was partly (in one mentor education programme) collected by administrators at a lecture attended by mentors, which resulted in a nearly 100% response rate from the mentors present. In the two other educational programmes, the same questionnaires were distributed to teacher education contacts in local practice schools, which distributed and collected the forms from the mentor teachers. Mentors attending mentor education were in programmes designed to provide guidelines and establish the purposes, learning goals, methods, content, extent and admission

criteria for school-based mentoring (The Norwegian Government, 2010). Gathering data from mentors in both mentor education programmes and their schools resulted in a mixed cohort of mentors: 35.3% of the mentors had mentor education. Almost all mentors, 98.5%, had mentored pre-service teachers before.¹

Table 1: Data Selection from Mentors in Three Teacher Education Programmes and Two Institutions (O and T)

Programmes	N
O_Upper secondary	66
T_Upper secondary	112
T_Upper secondary	43
T_Primary	74
Total	295

Table 2: Concepts, Cronbach's Alpha, Item Wording, Item Means and Standard Deviations, N = 272

<i>Mentor efficacy, $\alpha_c = .82$</i>	<i>Mean</i>	<i>Std. dev.</i>
I am sure that I can mentor the most insecure pre-service teacher to achieve good professional development in the practicum.	5.17	1.17
I am sure that I can answer the pre-service teachers' questions so that they experience support in their practicum.	5.73	0.96
I am sure that I can maintain good relationships even with pre-service teachers who are very different from me.	5.74	0.93
I am sure that I can mentor pre-service teachers in how to manage complex situations and dilemmas that arise in their teaching.	5.64	0.93
<i>Reflection-based mentoring, $\alpha = .43$</i>	<i>Mean</i>	<i>Std. dev.</i>
In dialogues with me as a mentor, it is very important that my mentee be given opportunities to reflect on his or her practices.	6.77	0.56
It is very important to communicate to my mentee that there are many ways to be a good teacher.	6.64	0.71
It is very important that my mentee be trained in formulating his or her own beliefs about learning and teaching.	6.11	1.01
<i>Clear mentoring, $\alpha_c = .73$</i>	<i>Mean</i>	<i>Std. dev.</i>

¹ An exploration of how the investigated mentors, from different contexts, differed from each other is presented in Sandvik *et al.* (forthcoming).

It is important for my mentee to receive clear instructions from me on how they should perform his or her teaching jobs.	4.81	1.47
It is important to contribute to my mentee's awareness of mistakes that he or she makes.	5.27	1.48
It is important that I contribute to my mentee's awareness of having done something inappropriate if such a situation arises.	5.70	1.14
<i>Mentor effort, $\alpha_c = .80$</i>	<i>Mean</i>	<i>Std. dev.</i>
I prioritise the mentoring role even when I am very busy with other things.	5.83	1.04
I am trying to fulfil my mentoring role as well as I possibly can.	6.53	0.68
It is very important for me to have an influence as a mentor.	6.03	0.98
I often put extra effort into the role of mentor.	5.24	1.40

Analysis

SEM was used to analyse the relationships among the variables. Based on the theoretical assumptions and data exploration, a structural model was set up. In the estimated models, ellipses represent the latent variables, circles represent measurement errors and rectangles represent observed items. The structural model consists of terms with paths (arrows) between them. The path arrows indicate theoretical common causes, and the numbers, which are standardised regression coefficients, display the measured strengths of the connections. The strength of a connection increases with the numerical value. Assessments of fit between the models and the data were based on the following indices: the p -value (the probability of observing a test statistic, labelled p -chi), the root mean square error of approximation (RMSEA), the Tucker–Lewis index (TLI), the goodness-of-fit index (GFI) and the comparative fit index (CFI) (p -chi >.05; RMSEA <.05; and TLI, GFI and CFI >.95 indicated good fit, while RMSEA <.08 and TLI, GFI and CFI >.90 indicated acceptable fit (Byrne, 2010; Kline, 2005). The model was estimated using IBM SPSS AMOS 22. The values presented below indicate that the structural models presented in Figures 2 and 3 approach the outer boundary of an acceptable fit. More precisely, the p -value of .047 is close to .05, a point at which rejection would normally be recommended. The RMSEA value of .033 results indicates a good fit. The TLI of .892 is close to the norm of .90, indicating an acceptable fit. The GFI value of .951 indicates a good fit, and the CFI value of .916 indicates an acceptable fit. Given that contrasting models are presented and discussed, we argue that the models are appropriate foundations for the presented discussions. Figure 4 shows an alternative model based on a two-item representation of the reflection-based mentoring construct. The fit scores overall indicated a better fit than with three indicators as used in Figures 2 and 3. However, due to substantial considerations, Figures 2 and 3 devoted most attention in the interpretation of the results.

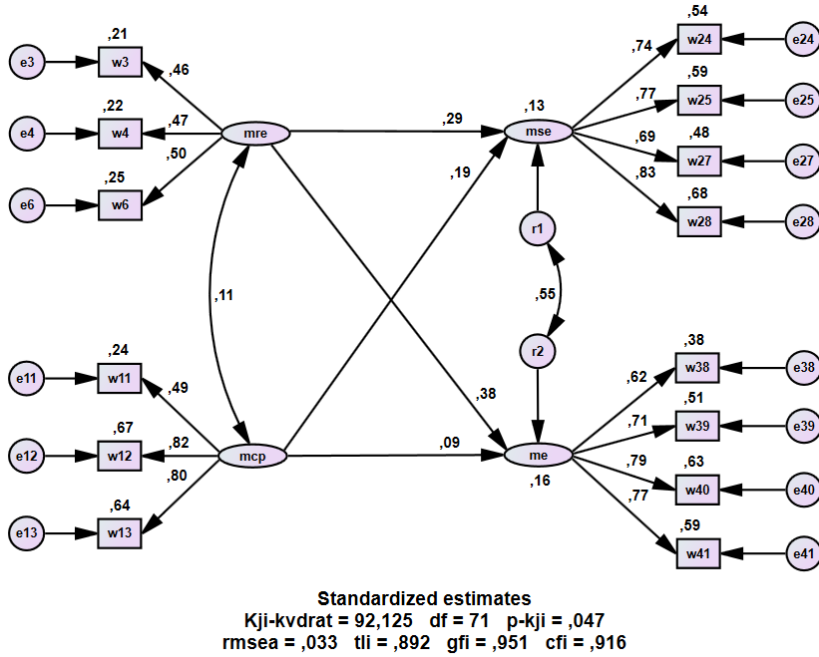

Figure 2. Estimated model ($N = 295$). MSE = mentor self-efficacy; ME = mentor's effort in the role of mentor; MCP = mentor's support for clear mentoring; MRE = mentor's support for reflection-based mentoring.

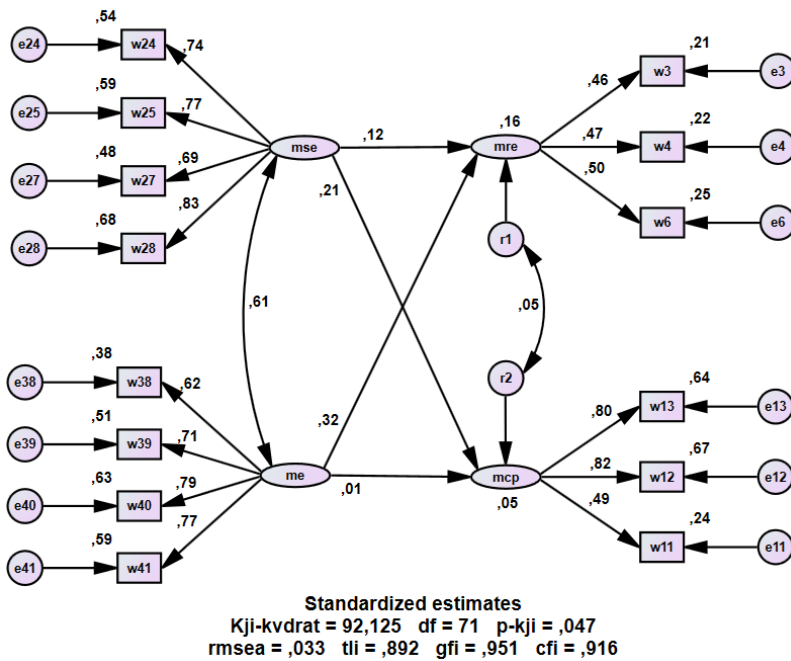

Figure 3. Estimated model ($N = 295$). MSE = mentor self-efficacy; ME = mentor's effort in the role of mentor; MCP = mentor's support for clear mentoring; MRE = mentor's support for reflection-based mentoring.

Alternative model

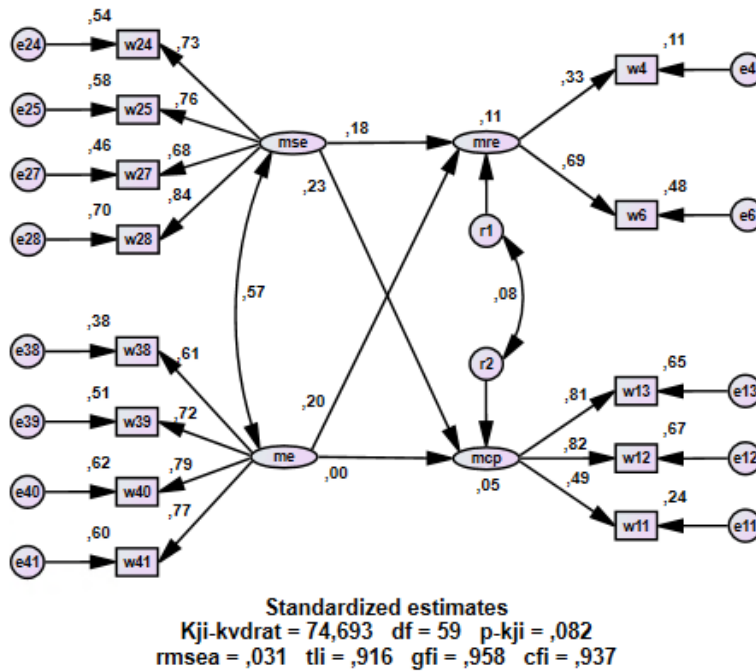

Figure 4. Estimated model ($N = 295$) with two instead of three indicators used to operationalise reflection-based mentoring. MSE = mentor self-efficacy; ME = mentor's effort in the role of mentor; MCP = mentor's support for clear mentoring; MRE = mentor's support for reflection-based mentoring.

Results

The results of the analysis show that mentors' self-efficacy is only moderately related to support for clear mentoring ($b_{(MCP \rightarrow MSE)} = .19$ in Figure 2 and $b_{(MSE \rightarrow MCP)} = .21$ in Figure 3) and with reflection-based mentoring ($b_{(MRE \rightarrow MSE)} = .29$ in Figure 2 and $b_{(MSE \rightarrow MRE)} = .12$ in Figure 3), indicating that mentors' level of confidence in their mentor role is related to more positive opinions about both tested approaches in mentoring. These findings moderately support Hypotheses 1 ("mentors' self-efficacy is related to clear mentoring") and 2 ("mentors' self-efficacy is related to reflection-based mentoring").

Mentor effort in the mentoring role is more strongly associated with support for reflection-based mentoring ($b_{(MRE \rightarrow ME)} = .38$ in Figure 2 and $b_{(ME \rightarrow MRE)} = .32$ in Figure 3). These findings indicate that those who put more effort into the mentor role also have more positive opinions about mentees' reflections as a key to success in mentoring, supporting Hypothesis 3 ("mentor effort is related to mentors' support for reflection-based mentoring"). Effort was not strongly related to support for clear mentoring ($b_{(MCP \rightarrow ME)} = .09$ in Figure 2 and $b_{(ME \rightarrow MCP)} = .01$ in Figure 3), indicating that mentors' priority of the mentor role was not important in creating their opinions about offering advice and instructions as they mentor. Hypothesis 4 ("mentor effort is related to mentors' support for clear mentoring") was not significantly supported by these results.

The investigation related to Exploratory Assumption 1 shows that mentor effort was strongly associated with mentor self-efficacy ($r_{(ME \leftrightarrow MSE)} = .55$ in Figure 2 and $.61$ in Figure 3). This finding indicates that mentors who are more self-confident in their role also tend to put more effort into their mentorship.

In line with Exploratory Assumption 2, we also explored how the constructs of reflection-based mentoring and clear mentoring were associated. Our results indicated little overlap between these two latent variables ($r_{(MRE \leftrightarrow MCP)} = .11$ in Figure 2 and $.05$ in Figure 3). Although there were challenges related to the low CA values for reflection-based mentoring, this finding indicates that the constructs capture distinct phenomenon. At the same time, it indicates that mentors' support for reflection-based mentoring was not related to support for clear mentoring. Some mentors reported high support for clear mentoring and low support for reflection-based mentoring, and vice versa. As such, there were no evident patterns in the respondents' answers.

Discussion and implications

This article contributes to the field of mentoring by illuminating the interrelationships between mentors' support for different forms of mentoring, mentors' self-efficacy and their commitment to the role of mentoring. Our hypothesised model (Figure 1) illustrated theoretically based assumptions about how mentors' support for reflection-based and clear mentoring could be related to mentors' self-efficacy and effort. The results from the presented empirical testing of this model extend existing knowledge about mentors' preferences and priorities and the relationship between mentors' self-efficacy, effort and preferred mentoring strategies. The hypothesised model was strengthened by results supporting Hypotheses 1, 2 and 3. However, the results did not support Hypothesis 4. We illustrate our conclusions about the hypothesised model by presenting our empirical testing in two models in which the causal arrows point in opposite directions. We also contribute to knowledge relevant for research on different forms of mentoring by developing and testing constructs that can illuminate mentors' support for reflection-based mentoring and clear mentoring.

In Table 2, we presented descriptive statistics relevant to understanding Norwegian mentors' preferences for different mentoring approaches. More precisely, we found that the mean for support for reflection-based mentoring ranged from 6.1 to 6.8 (on a 1–7 scale). The mean for support for clear mentoring ranged from 4.8 to 5.7 (on a 1–7 scale). Together, these results indicate that mentors support both mentees' reflection and approaches where mentors share their opinions. However, mentors value reflection-based approaches higher than clear mentoring. This aligns with other findings that indicate a stronghold of support for mentees' reflection and room for exploration of own practise in Scandinavian mentoring. Since previous research has identified that Norwegian mentors tend to execute more direct approaches, although they value reflection-based approaches more (Sundli, 2007), we can assume that the actual mentoring these mentors performed was characterised by variation. Such findings remind us that mentors' beliefs are not necessarily consistent with how they mentor others.

The findings in this article contribute to knowledge about how mentors' beliefs about mentoring are related to other mentor characteristics. This is important given that positive outcomes of mentoring do not necessarily occur (Eby *et al.*, 2004; Harrison *et al.*, 2006; Hobson and Malderez, 2013; Hobson

et al., 2009; Kram, 1988). A deeper assessment of the conditions promoting different forms of mentoring can benefit beginning teachers. For instance, the relationship that emerges between mentor efficacy and support for different forms of mentoring (investigated through Hypotheses 1 and 2) is of interest.

In addition to testing whether higher levels of mentor efficacy were related to greater support for sharing of mentors' perspectives in mentoring (Lejonberg *et al.*, 2015), the current study also characterised the relationship between mentors' self-efficacy and their support for mentoring styles by presenting two models with causal arrows pointing in opposite directions. The relationships between these two styles of mentoring and mentor efficacy, as a dependent variable, could mirror the experience by which both forms of mentoring can contribute to higher levels of self-efficacy for mentors.

The findings indicating that support for reflection-based mentoring is more strongly related to self-efficacy than support for clear mentoring (Figure 2) could be related to the findings in previous studies that reflection-based approaches to mentoring have a privileged place in Norwegian mentor training. However, on the contrary, the reversed model expands this picture. In Figures 3 and 4, where self-efficacy is one of the independent variables, the results indicate a stronger relationship between mentor self-efficacy and clear mentoring than between self-efficacy and reflection-based mentoring. Such mixed evidence illuminates the complexity of relationships between variables such as mentors' beliefs and mentor characteristics and shows why presenting different SEM models is an appropriate analysis method. A possible interpretation of these results relates to findings that mastery experiences were the strongest predictors of teacher self-efficacy (Bandura, 1997; Hoy and Spero, 2005; Tschannen-Moran, 2007). Since mentees often seek clear feedback from mentors (Joram, 2007; Sundli, 2002), those mentors who provided advice and communicated their perspectives and experiences were likely to perceive that they were fulfilling mentees' expectations, leading to a sense of mastery as a mentor.

Committing to the mentor role is challenging as it demands that mentors move beyond their identity as teachers (Bullough, 2005). Consequently, it is important to separate mentors' effort in the mentor role from their work as teachers. In this article, we presented a construct to measure mentor effort as well as indicate that mentors' efforts were related to their support for different approaches in mentoring. In line with Hypothesis 3, we found that mentors who reported higher levels of effort also reported higher levels of support for reflection-based mentoring. However, higher levels of support for clear mentoring were not related to reported effort (Hypothesis 4 was therefore not supported). This is relevant considering claims that advice giving or sharing one's practical experience is seen as a less complex approach to mentoring. Using the competencies and preferences of the mentee as a starting point for encouraging his or her professional development is seen as a more complex approach (Hobson and Malderez, 2013; Lejonberg *et al.*, 2015; Loughran and Russell, 1997). The more complex approach is not necessarily better suited for promoting student teachers' development. Earlier

work indicated that mentors' perspectives and clarity were useful for mentees (Lejonberg and Tiplic, 2016). Although the assumption that mentors' reported efforts indicate how hard they actually work is problematic, the survey results indicated a clear pattern connecting mentors' preferences to their reported effort: support for reflection-based mentoring is related to higher levels of effort in the mentoring work, while support for clear mentoring is not.

In relation to the uncertainty concerning the direction of any causal relationships, an interesting issue for further research is whether the mentors who are more committed and willing to go beyond their role for their mentees choose reflection-based methods or whether reflection-based approaches demand more of mentors. In either of these interpretations, the survey results corroborated what others have argued: reflection-based methods are demanding for both mentors and mentees. If alternative methods can be more effective, as some studies have suggested, additional evidence would be needed to support mentor training that emphasises reflection as the preferred method of mentoring. The mentors who have higher beliefs in reflection-based methods may work harder to achieve results, but whether they are more likely to succeed is a different question.

As mentioned, several of the informants in this study were approached while undergoing mentor education. This context implies that they were in the process of discussing and developing their evaluations of various forms of mentoring (Lejonberg *et al.*, 2015; Ulvik and Sunde, 2013). Lejonberg *et al.* (2015) and Thornton (2014) argued that in-depth professional learning opportunities can make mentors less likely to exercise judgemental mentoring. Bradbury and Koballa (2008) called for further exploration of "ways to balance the need for mentors to provide direction while still allowing the intern to find his/her own teacher identity" (p. 2143). Together with other contributions that distinguish and identify different forms of mentoring and their possible effects on mentees (Eby *et al.*, 2004; Evertson and Smithey, 2000; Feiman-Nemser, 2001), the results presented in this study lay the groundwork for professional learning opportunities. Mentor education can promote mentor development by inviting discussions about different approaches to mentoring and the relationships with effort and mentors' professional self-confidence.

Considering the complexity of mentoring beginning teachers, as well as evidence that challenges assumptions about various mentoring styles, we argue that in mentor training, mentors should discuss and practice mentoring based on awareness of a wide range of approaches. Lejonberg *et al.* (2015) argued that training can affect mentors' preferred forms of mentoring. This argument is based on evidence indicating that mentor education results in lower support for mentoring characterised by clear feedback and advice. Others found that trained mentors differ from untrained mentors in that they show a tendency to guide their mentees through self-discovery of knowledge about teaching (Crasborn *et al.*, 2008). A balance between facilitating reflection on the one hand and guiding on the other is not easy for mentors to master. However, such skills can be improved if mentors practice these skills in mentor training (Crasborn *et al.*, 2008; Evertson and Smithey, 2000; Hyland, 1992; Thornton, 2014). Since mentors' support for different mentoring styles and their self-efficacy and willingness to

prioritise their mentorship are related, the findings presented here call for a more multifaceted approach when training mentors. If reflection-based mentoring demands more effort in the mentoring role, its effect should be discussed in mentor education. In addition, if a clearer approach to mentoring practice results in higher mentor efficacy, this possible consequence should also be taken into consideration in mentor training. Considering that mentor education in Norway is a relatively new phenomenon, further research is needed to achieve more knowledge about how mentors develop in such processes.

The alpha value of reflection-based mentoring indicated that the theoretically based constructs are elusive and hard to grasp (Tschannen-Moran and Hoy, 2001). Although our used items (focusing on mentors emphasising mentees' opportunities to reflect, openness to different approaches to teaching and discussing mentees' beliefs about learning and teaching) are aligned with the theoretical descriptions of such approaches to mentoring, the empirical data shows that mentors do not necessarily perceive the different aspects coherently. For instance, a mentor who is preoccupied with giving mentees opportunities to reflect on their own practises in mentoring does not necessarily communicate to mentees that there are many ways to be a good teacher. School-based mentoring is a field where relatively little is done to develop tools for measuring approaches quantitatively. An avenue for future research could be to develop variables capturing different aspects included in the reflection-based mentoring construct. In addition, our evidence suggests that the potential direction of causality is not convincing at this point. More research on antecedent factors and possible outcomes of mentors' preferred forms of mentoring is required.

In relation to the first exploratory question, the results of this study point to a significant overlap between mentor effort and self-efficacy in this domain. These findings show that those who reported high levels of confidence in their abilities as mentors also reported higher levels of effort in the mentoring role. While others found that mastery experiences were the most potent sources of self-efficacy, our results suggest that those who believe they will perform well as mentors are motivated to put extra effort into their role.

The findings provide new insight into mentors' preferred mentoring strategies. In addition, as explored through the second exploratory question, the results indicate that support for different forms of mentoring does not overlap in this study. Keeping in mind the challenges related to consistency in the reflection-based mentoring construct, this implies that support for clear mentoring approaches is not relevant in mentors' opinions of reflection-based mentoring. This contradicts the findings presented in Lejonberg and Tiplic (2016) where clear mentoring overlapped with developmental mentoring, which is also based on reflection and openness. However, in the validation and construct development work prior to the current article, a new operationalisation of reflection-based mentoring was developed that differed from the previous conception of developmental mentoring in one key respect. In contrast to the earlier version, the construct presented here does not include statements related to trust and loyalty. That the overlap between clear mentoring and reflection-based mentoring

is so much smaller in our results than in previous studies indicates that loyalty and trust can be important factors in mentoring but are not specific to one form of mentoring and should not be indicators for distinguishing between different forms of mentoring. A further development of the reflection-based mentoring instrument is needed, as indicated by the low CA value. In this work, isolating different possible aspects included in the current variables would be of interest.

To sum up, the following implications can be drawn from this work:

- In mentor training, mentors should discuss and practice mentoring based on awareness of a wide range of approaches.
- Given that mentors who believe they will perform well as mentors are also motivated to put extra effort into their role, strengthening mentors' self-efficacy seems to be important in mentor training.
- When discussing reflection-based mentoring in mentor training, mentors' perceptions of this form of mentoring as demanding (related to higher levels of effort) should be thematised.
- Presenting SEM models with causal arrows in opposite directions can extend understanding of possible relations between variables.

Limitations and avenues for further research

This study had several shortcomings that should be acknowledged. First, it is important to emphasise that relatively little quantitative research has been carried out with participants in mentor training programmes, particularly in the education field. The present study should be followed up with other studies to add more explanatory variables to the theoretical model and further develop and validate the variables used. Omitted variables could also be influential. More factors should be included to identify which ones impact mentoring preferences most. A second issue is that longitudinal and quasi-experimental studies are needed to validate inferences about causality. A cross-sectional study, like this one, can only represent a snapshot of mentors' preferred forms of mentoring, and causal relationships with presumed antecedents cannot be tested. The dynamics that connect support for different forms of mentoring with mentors' sense of self-efficacy and mentor effort are hard to untangle, and the present cross-sectional design does not permit examination of such potential causal linkages. Preferences and perceptions (such as mentor efficacy) precede actions, but preferred forms of mentoring operate in the opposite direction to the assumptions in this paper's hypothetical model. More research along the same lines would help interpret any causal relationships and identify the mechanisms that could be responsible for what was measured here.

Another improvement would be to examine some cases in depth to attain a better understanding of the phenomena. There is a need to consider the results of these surveys in tandem with qualitative studies of mentors' preferences and actions. Further research is needed to determine how mentors'

perceptions and preferences emerge. It would also be of interest to replicate this study in other contexts, both in other countries and in other Norwegian cohorts. Although this paper's empirical data was gathered from mentors from the two largest teacher education training programmes in Norway, a final limitation is the moderate size of the sample. As such, these limitations provide ample opportunities for productive research in the future.

The use of self-reported questionnaire data also presents a shortcoming. The subjective component of such data is undeniable, and how the items are formulated could affect the results. In addition, there was no opportunity in this study to couple self-reported data to mentors' measured task performance. However, used alongside qualitative data, the findings presented in this work could identify significant aspects of practice for mentoring beginning teachers.

References

- Arbuckle, J. and Wothke, W. (1999), *Amos 4.0 User's Guide: SPSS*. Smallwaters Corporation.
- Aspfors, J. and Fransson, G. (2015), "Research on mentor education for mentors of newly qualified teachers: A qualitative meta-synthesis", *Teaching and Teacher Education*, Vol. 48, pp. 75-86.
- Augustiniene, A., and Ciuciulkiene, N. (2013). Reverse Mentoring as Facilitating Factor for the Development of a Beginning Teacher's Self-Authorship Process. *Social Sciences*, 81(3), 73-84.
- Bandura, A. (1997), *Self-efficacy: The exercise of control*, Freeman, New York.
- Bentler, P. M. and Chou, C.-P. (1987), "Practical issues in structural modeling", *Sociological Methods and Research*, Vol. 16 No 1, pp. 78-117.
- Berger, J.-L., Girardet, C., Vaudroz, C. and Crahay, M. (2018), "Teaching Experience, Teachers' Beliefs, and Self-Reported Classroom Management Practices: A Coherent Network", *SAGE Open*, Vol. 8 No. 1, pp. 1-12.
- Bishop, P. A. and Herron, R. L. (2015), "Use and misuse of the likert item responses and other ordinal measures", *International journal of exercise science*, Vol. 8 No. 3, pp. 297.
- Bjerkholt, E. (2013). *Åpning av lukkede rom: en kvalitativ studie av innholdet og dialogene i veiledningssamtaler mellom nyutdannede lærere og lokale veiledere [Opening of Closed Rooms: a qualitative study of the content and dialogues in mentoring talks between newly qualified teachers and local mentors]* (Vol. nr. 168). Oslo: Unipub forlag.
- Bjerkholt, E., Ødegård, E., Søndena, K. and Hjordemaal, F. R. (2014), "Hvordan kan veiledningssamtaler åpne for kritisk tenkning?" ["How can mentoring open for critical thinking"], *Uniped*, Vol. 37 No. 4, pp. 19-31.
- Blau, P. M. (1964), *Exchange and power in social life*, Transaction Publishers, New York.
- Bradbury, L. U., and Koballa Jr, T. R. (2008). Borders to cross: Identifying sources of tension in mentor–intern relationships. *Teaching and Teacher Education*, 24(8), 2132-2145.

- Brondyk, S., and Searby, L. (2013). Best practices in mentoring: complexities and possibilities. *International Journal of Mentoring and Coaching in Education*, 2(3), 189-203.
- Brown, T. A. (2006), *Confirmatory factor analysis for applied research*, Guilford Press, New York.
- Bruner, J. S. (1996). *The culture of education*. Cambridge, MA: Harvard University Press.
- Byrne, B. M. (2013), *Structural equation modeling with Mplus: Basic concepts, applications, and programming*, Routledge, Ottawa, Canada.
- Bullough Jr, R. V. (2005). Being and becoming a mentor: school-based teacher educators and teacher educator identity. *Teaching and Teacher Education*, 21(2), 143-155.
- Byrne, B. M. (2010). *Structural equation modeling with AMOS: Basic concepts, applications, and programming*. Ottawa, Canada: Routledge.
- Canrinus, E. T., Helms-Lorenz, M., Beijaard, D., Buitink, J. and Hofman, A. (2012), "Self-efficacy, job satisfaction, motivation and commitment: exploring the relationships between indicators of teachers' professional identity", *European journal of psychology of education*, Vol. 27 No. 1, pp. 115-132.
- Clutterbuck, D. (2004), *Everyone needs a mentor: Fostering talent in your organisation*: CIPD Publishing, London, UK.
- Clutterbuck, D. and Abbott, P. (2005), "Mentoring as an empowerment tool", Retrieved from <http://clutterbuckassociates.co.za/wp-content/uploads/2011/04/Mentoring-as-an-Empowerment-Tool.pdf>
- Crasborn, F., Hennissen, P., Brouwer, N., Korthagen, F. and Bergen, T. (2008), "Promoting versatility in mentor teachers' use of supervisory skills", *Teaching and Teacher Education*, Vol. 24 No. 3, pp. 499-514.
- Dahl, T. (2006). *Hjelp til praksisspranget. Evaluering av veiledning av nyutdannede lærere [Help for the practice jump. Evaluation of mentoring of newly qualified teachers]*. Retrieved from: http://www.udir.no/Upload/Rapporter/5/evaluering_av_nyutdannede_laerere.pdf?eps langu age=no
- Eby, L., Butts, M., Lockwood, A., and Simon, S. A. (2004). Protégés negative mentoring experiences: Construct development and nomological validation. *Personnel Psychology*, 57(2), 411-447.
- Evertson, C. M. and Smithey, M. W. (2000), "Mentoring effects on proteges' classroom practice: An experimental field study", *The Journal of Educational Research*, Vol. 93 No. 5, pp. 294-304.
- Fang, Z. (1996), "A review of research on teacher beliefs and practices", *Educational Research*, Vol 38 No. 1, pp. 47-65.
- Feiman-Nemser, S. (2001), "Helping novices learn to teach lessons from an exemplary support teacher", *Journal of teacher education*, Vol. 52 No. 1, pp. 17-30.

- Fenwick, T. (2013), "Understanding transitions in professional practice and learning: Towards new questions for research", *Journal of Workplace Learning*, Vol. 25 No. 6, pp. 352-367.
- Furlong, J. (1995). The limits of competence. In T. Karry and A. S. Mayes (Eds.), *Issues in Mentoring* (pp. 225-231). London: Routledge.
- Grossman, P., Loeb, S., Cohen, J., Hammerness, K., Wyckoff, J., Boyd, D. and Lankford, H. (2010), "Measure for measure: The relationship between measures of instructional practice in middle school English Language Arts and teachers' value-added scores", Retrieved from <https://www.urban.org/sites/default/files/publication/33246/1001425-Measure-for-Measure-The-Relationship-between-Measures-of-Instructional-Practice-in-Middle-School-English-Language-Arts-and-Teachers-Value-Added-Scores.PDF>
- Haladyna, T. M., and Rodriguez, M. C. (2013). *Developing and validating test items*. New York: Routledge
- Handal, G. (2007), "Veilederen - guru eller kritisk venn?" ["The mentor - guru or critical friend"], in Kroksmark, T. and Åberg, K. (Eds.), *Veiledning i pedagogisk arbeid*, Fagbokforlaget, Bergen, pp. 23-33.
- Handal, G. and Lauvås, P. (1987), *Promoting reflective teaching: Supervision in practice*. Philadelphia, PA: Milton Keynes: Society for Research into Higher Education and Open University Press.
- Handal, G. and Lauvås, P. (1983), *På egne vilkår [On own terms]*, Cappelen forlag, Otta.
- Harrison, J., Dymoke, S. and Pell, T. (2006), "Mentoring beginning teachers in secondary schools: An analysis of practice", *Teaching and Teacher Education*, Vol. 22 No. 8, pp. 1055-1067.
- Hartberg, E. W., Dobson, S, and Gran, L. (2012), *Feedback i skolen [Feedback in school]*, Gyldendal akademisk, Oslo.
- Hattie, J. (2009), *Visible learning: A synthesis of 800+ meta-analyses on achievement*, Routledge, Abingdon.
- Hattie, J. and Timperley, H. (2007), "The power of feedback", *Review of Educational Research*, Vol. 77 No. 1, pp. 81-112.
- Helms-Lorenz, M., Slob, B., and van de Grift, W. (2013). First year effects of induction arrangements on beginning teachers' psychological processes. *European journal of psychology of education*, 28(4), 1265-1287.
- Hobson, A. J., Ashby, P., Malderez, A. and Tomlinson, P. D. (2009), "Mentoring beginning teachers: What we know and what we don't", *Teaching and Teacher Education*, Vol. 25 No. 1, pp. 207-216.
- Hobson, A. J. and Malderez, A. (2013), "Judgementoring and other threats to realizing the potential of school-based mentoring in teacher education", *International Journal of Mentoring and Coaching in Education*, Vol. 2 No. 2, pp. 89-108.

- Hobson, A. J., and McIntyre, J. (2013). Teacher fabrication as an impediment to professional learning and development: the external mentor antidote. *Oxford Review of Education*, 39(3), 345-365.
- Hoy, A. W. and Spero, R. B. (2005), "Changes in teacher efficacy during the early years of teaching: A comparison of four measures", *Teaching and Teacher Education*, Vol. 21 No. 4, pp. 343-356.
- Hudson, P. (2005), "Identifying mentoring practices for developing effective primary science teaching", *International Journal of Science Education*, Vol. 27 No. 14, pp. 1723-1739.
- Hyland, T. (1992), "Expertise and competence in further and adult education", *Journal of In-Service Education*, Vol. 18 No. 1, pp. 23-28.
- Irby, B. J. (2014). Editor's Overview: A 20-Year Content Review of Research on the Topic of Developmental Mentoring Relationships Published in the Mentoring & Tutoring Journal. *Mentoring & Tutoring: Partnership in Learning*, 22(3), 181-189.
- Joram, E. (2007), "Clashing epistemologies: Aspiring teachers', practicing teachers', and professors' beliefs about knowledge and research in education", *Teaching and Teacher Education*, Vol. 23 No. 2, pp. 123-135.
- Kirschner, P. A., Sweller, J. and Clark, R. E. (2006), "Why minimal guidance during instruction does not work: An analysis of the failure of constructivist, discovery, problem-based, experiential, and inquiry-based teaching", *Educational psychologist*, Vol. 41 No. 2, pp. 75-86.
- Kline, R. B. (2005). *Principles and Practice of Structural Equation Modeling*. 2005. New York: Guilford.
- Kram, K. E. (1988), *Mentoring at work: Developmental relationships in organizational life*, University Press of America, Maryland, USA.
- Kullman, J. (1998), "Mentoring and the development of reflective practice: Concepts and context", *System*, Vol. 26 No. 4, pp. 471-484.
- Lejonberg, E. (2016). *Hva kan bidra til god veiledning? En problematisering basert på veilederes og veisøkeres perspektiver på veiledning av begynnende lærere [What can contribute to beneficial mentoring? A problematization based on mentors' and mentees' perspectives on mentoring of beginning teachers]*. (Phd), University of Oslo, Oslo.
- Lejonberg, E., & Christophersen, K.-A. (2015). School-based mentors' affective commitment to the mentor role: Role clarity, self-efficacy, mentor education and mentor experience as antecedents. *International Journal of Evidence Based Coaching and Mentoring*, 13(2).
- Lejonberg, E., Elstad, E., & Christophersen, K.-A. (2015). Mentor education: challenging mentors' beliefs about mentoring. *International Journal of Mentoring and Coaching in Education*, 4(2), 142-158.
- Lejonberg, E., & Tiplic, D. (2016). Clear Mentoring: Contributing to Mentees' Professional Self-confidence and Intention to Stay in their Job. *Mentoring & Tutoring: Partnership in Learning*, 1-16.

- Lindgren, U. (2005), "Experiences of beginning teachers in a school-based mentoring program in Sweden", *Educational studies*, Vol. 31 No. 3, pp. 251-263.
- Lindgren, U. (2007). New into the profession: a study of the mentoring of novice teachers in Sweden. *Journal of In-Service Education*, 33(2), 241-243.
- LoCasale-Crouch, J., Davis, E., Wiens, P. and Pianta, R. (2012), "The role of the mentor in supporting new teachers: Associations with self-efficacy, reflection, and quality", *Mentoring and Tutoring: Partnership in Learning*, Vol. 20 No. 3, pp. 303-323.
- Loughran, J. and Russell, T. (1997), "Meeting student teachers on their own terms: Experience precedes understanding", in Richardson, V. (Ed.), *Constructivist teacher education: Building a world of new understandings*, Routledge, Abingdon, pp. 164-181.
- Mathisen, P. (2015). *Mentor: mentoring i teori og praksis [Mentor: mentoring in theory and practice]* (2. utg. ed.). Bergen: Fagbokforlaget.
- Mathisen, P., and Bjørndal, C. (2007). Forord [Preface]. In T. Kroksmark & K. Åberg (Eds.), *Veiledning i pedagogisk arbeid [Mentoring in educational work]* (pp. 5-13). Bergen: Fagbokforlaget.
- Ministry of Education and Research, 2017
- NRLU. (2017), Nasjonale retningslinjer for praktisk pedagogisk utdanning [National guidelines for practical pedagogical education], retrived from http://www.uhr.no/documents/Godkjente_retningslinjer_PPU.pdf.
- Orland-Barak, L. (2014), "Mediation in mentoring: A synthesis of studies in Teaching and Teacher Education", *Teaching and Teacher Education*, Vol. 44 No. 0, pp. 180-188.
- Ottesen, E. (2006), *Talk in practice: Analysing student teachers' and mentors' discourse in internship*, Doctoral thesis, University of Oslo, Norway.
- Payne, S. C., and Huffman, A. H. (2005). A longitudinal examination of the influence of mentoring on organizational commitment and turnover. *Academy of Management Journal*, 48(1), 158-168.
- Penny, A. J., Harley, K. L. and Jessop, T. S. (1996), "Towards a language of possibility: critical reflection and mentorship in initial teacher education", *Teachers and Teaching: theory and practice*, Vol. 2 No. 1, pp. 57-69.
- Rambøll. (2016). *Veiledning av nyutdannede barnehagelærere og lærere: en evaluering av veiledningsordningen og veilederutdanningen [Mentoring of newly-educated kindergarten teachers and teachers: an evaluation of the mentoring scheme and mentor education]*. Retrieved from <https://www.udir.no/globalassets/filer/tall-og-forskning/rapporter/2016/evaluering-av-veiledningsordningen-sluttrapport.pdf>
- Reeve, J. (2009), "Why teachers adopt a controlling motivating style toward students and how they can become more autonomy supportive", *Educational psychologist*, Vol. 44 No. 3, pp. 159-175.

- Richard, O. C., Ismail, K. M., Bhuian, S. N. and Taylor, E. C. (2009), "Mentoring in supervisor–subordinate dyads: Antecedents, consequences, and test of a mediation model of mentorship", *Journal of Business Research*, Vol. 62 No. 11, pp. 1110-1118.
- Richter, D., Kunter, M., Lüdtke, O., Klusmann, U., Anders, Y., and Baumert, J. (2013). How different mentoring approaches affect beginning teachers' development in the first years of practice. *Teaching and Teacher Education*, 36, 166-177.
- Sandvik, L., Solhaug, T., Lejonberg, E., Elstad, E., & Christophersen, K. A., (forthcoming). School mentors' perceived integration into teacher education programmes.
- Skaalvik, E. M. and Skaalvik, S. (2007), "Dimensions of teacher self-efficacy and relations with strain factors, perceived collective teacher efficacy, and teacher burnout", *Journal of Educational Psychology*, Vol. 99 No. 3, pp. 611-625.
- Skagen, K. (2013). *I veiledningens landskap: innføring i veiledning og rådgivning [In the landscape of mentoring: introduction to mentoring and guidance]*. Oslo: Cappelen Damm Akademisk.
- Skagen, K. (2016). Kunnskapstyper og hegemonisk veiledningsstrategi i norsk veiledningsdiskurs [Knowledge types and hegemonic mentoring strategy in Norwegian mentoring discourse]. In A.-L. Østern & G. Engvik (Eds.), *Veiledningspraksiser i bevegelse. Skole, utdanning og kulturliv [Mentoring practices in motion. School, education and cultural life]* (pp. 59-77). Oslo: Fagbokforlaget.
- Smith, K. (2016). Partnerships in Teacher Education - Going Beyond the Rhetoric, with Reference to the Norwegian Context *CEPS Journal*, 6(3), 17.
- Smith, K., and Ulvik, M. (2014). Learning to teach in Norway: A shared responsibility. In O. McNamara (Ed.), *Workplace Learning in Teacher Education* (pp. 261-277). Dordrecht, the Netherlands: Springer Publishing Company
- Smith, T. M., and Ingersoll, R. M. (2004). What are the effects of induction and mentoring on beginning teacher turnover? *American educational research journal*, 41(3), 681-714.
- Sundli, L. (2001). *Veiledning i lærerutdanningens praksis: mellom refleksjon og kontroll [Mentoring in teacher training practicum: between reflection and control]*. (2001 nr 15), Høgskolen i Oslo, Avdeling for lærerutdanning, Oslo.
- Sundli, L. (2002), *Veiledning i virkeligheten, praksisveiledning med lærerstudenter [Mentoring in real life, mentoring in practicum]*, Gyldendal akademisk, Oslo.
- The Department of Education and Research. (2017). *Lærerutdanning 2025. Nasjonal strategi for kvalitet og samarbeid i lærerutdanningene [Teacher education 2025. National strategy for quality and cooperation in teacher education]*. Retrived from https://www.regjeringen.no/contentassets/d0c1da83bce94e2da21d5f631bbae817/kd_nasjonal-strategi-for-larerutdanningene_net.pdf.

- The Norwegian Government. (2010). *Veilederutdanning av mentorer for nyutdannede lærere - forslag til rammer for utdanningen [Mentor education of mentors for newly qualified teachers - proposal for a framework for education]*. Retrieved from https://www.regjeringen.no/globalassets/upload/kd/vedlegg/uh/gnist/veilederutdanning_arbeidsgrupperapport.pdf
- Thornton, K. (2014), "Mentors as educational leaders and change agents", *International Journal of Mentoring and Coaching in Education*, Vol. 33 No. 1, pp. 18-31.
- Tickle, L. (1993), "Capital T teaching", In Elliott, J. (Ed.), *Reconstructing Teacher Education*, The Falmer Press, London, pp. 110-124.
- Tschannen-Moran, M. (2007), "The differential antecedents of self-efficacy beliefs and novice and experienced teachers", *Teaching and Teacher Education*, Vol. 23, pp. 944-956.
- Tschannen-Moran, M. and Hoy, A. W. (2001), "Teacher efficacy: Capturing an elusive construct", *Teaching and Teacher Education*, Vol. 17 No. 7, pp. 783-805.
- Tschannen-Moran, M. and Hoy, A. W. (2007), "The differential antecedents of self-efficacy beliefs of novice and experienced teachers", *Teaching and Teacher Education*, Vol. 23 No. 6. pp. 944-956.
- Tschannen-Moran, M., Hoy, A. W. and Hoy, W. K. (1998), "Teacher efficacy: Its meaning and measure", *Review of Educational Research*, Vol. 68 No. 2, pp. 202-248.
- Ulvik, M., and Smith, K. (2011). En profesjon innenfor profesjonen [A profession within the profession]. *Bedre skole*(4), 82-87.
- Ulvik, M., and Sunde, E. (2013). The impact of mentor education: does mentor education matter? *Professional Development in Education*, 39(5), 754-770.
- Voerman, L., Meijer, P. C., Korthagen, F. and Simons, R. J. (2015), "Promoting effective teacher-feedback: from theory to practice through a multiple component trajectory for professional development", *Teachers and Teaching*, Vol. 21 No. 8 pp. 990-1009.
- Wildman, T. M., Magliaro, S. G., Niles, R. A., and Niles, J. A. (1992). Teacher mentoring: An analysis of roles, activities, and conditions. *Journal of teacher education*, 43(3), 205-213.
- Yost, D. S. (2006). Reflection and self-efficacy: Enhancing the retention of qualified teachers from a teacher education perspective. *Teacher Education Quarterly*, 33(4), 59-76.